

RIBBED PIPE HEAT EXCHANGER

RWT

OPERATING AND INSTALLATION INSTRUCTIONS

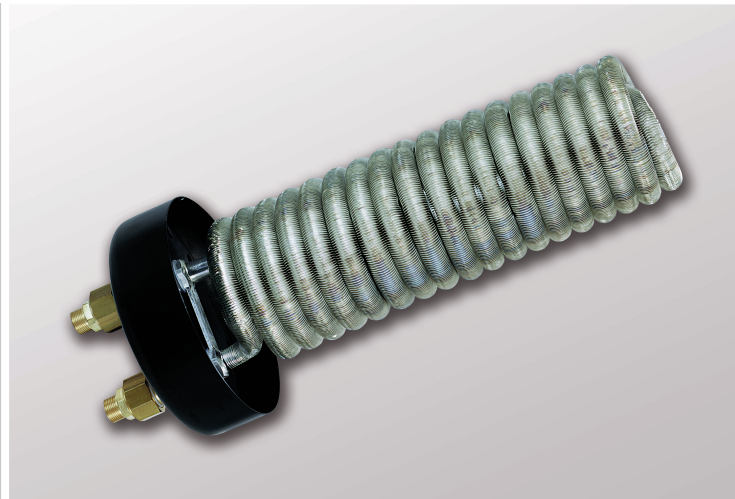

Misprints and technical changes reserved.
Please forward this on to the user!

Id.Nr.: 179390-5

AE
Austria Email

RIBBED PIPE HEAT EXCHANGER RWT

The heating coils are suitable for the heating of hot water storage tanks with the following heating media:

Heating water, district heating water, district heating steam

**Thermal media such as
Antifrogen L, Antifrogen N, PKL 100, PKL 300**

Maximum permissible internal operating pressure: 10.0 bar

Maximum permissible external operating pressure: 10.0 bar

Maximum permissible operating temperature: 95 °C

Description

Copper ribbed pipes are manufactured as seamless pipes using a process similar to thread rolling and all connection points are hard soldered with silver solder. After soldering the heating coils are electroplated with tin, coiled into a spiral form and fitted with a complete set of insulating connection screw joints and mounted, electrically isolated, on a flange plate.

For the reduction of thermal radiation the flange is covered by a lacquered cover of steel plate with a soft foam inlay on the inside. The compact design makes it possible to house high performance heating coils in the lowest area of the hot water storage tank. This is connected to an optimal exploitation of the entire storage volume for thermal absorption. In this way an advantageous circulation of the storage water for heat exchange purposes is also achieved. In addition the heating coils are characterised by a low degree of pressure loss on the inside of the pipe.

In general a circulation pump is required for the heating of the storage tank, which circulates the heating medium between the heat generator and the heating coil. By switching the circulation pump on and off via the temperature regulator, the temperature of the storage water can be regulated.

For installation in upright storage tanks, the ATR charging pump regulator + thermometer combination is suitable for this purpose.

Heating coils can also be arranged in the upper section of the hot water storage tanks and can be used for re-heating the storage water or for thermal extraction.

Through the installation of several independent heat exchangers it is possible to set up multivalent (connection to various energy supply systems) systems (e.g. in the upright storage tank product line, FFM).

Utilisation

Naturally it is possible to upgrade both new storage tanks, regardless of whether these are galvanized, enamelled or plastic coated, and existing systems through the installation of RWT-type ribbed pipe heat exchangers.

In case of extremely hard water and operation of the storage tank at temperatures above 60 °C, precautions should be taken in the form of de-calcification systems or else by implementing a regular cleaning regime (see Maintenance).

Installation Method

RWT-type ribbed pipe heat exchangers are usually installed horizontally in the upright storage tank. With due regard to the particular issues of system bleeding when installing from below, they can also be installed vertically, either from below or from above, whereby the changed flow characteristics need to be taken into consideration.

One thing to consider is that changes to the lengths of connection pipes due to temperature fluctuations need to be allowed for by expansion elements or suitable pipe conduits.

Electrically Isolated Installation and Connection Fittings

In general, magnesium or stray current anodes are built in to enamelled or plastic coated hot water storage tanks of steel in order to protect the base metal from corrosion at points with an insufficient coating. This cathodic corrosion protection is put at risk through the installation of electrically non-insulated heating coils, whereby the anodes will be exhausted within in a relatively short time. The faulty areas combine with the finer material of the heating coils to produce a galvanic element, which can lead to a rapid dissolution of the base material at the faulty area. Insulated connection fittings prevent the generation of these galvanic elements thereby making a significant contribution to the corrosion protection of coated steel hot water storage tanks.

A protective current bleeder resistor is integrated into the heat exchanger to protect it from current leakage corrosion.

Our insulated screw fittings isolate the heating coils both from the walls of the storage heater and from the metal connection pipework and therefore comply with DVGW- Worksheet W 511.

Corrosion Protection with Mixed Installations

The corrosion resistance of the copper to drinking water has been proven through long-term usage. In particular, Cu has proved to be an especially good material in the frequently encountered chloride contents of drinking water. In addition, the heating coils meet the conditions set out in DIN 1988 and DIN 4753.

If copper comes into contact with water, the copper ions are released into the water. The copper pipes are not at risk as, within a short period, a bonded protective layer is formed.

However these copper ions released into the water can quickly lead to corrosion damage in downstream galvanized steel pipes.

Therefore to avoid corrosion problems in relation to mixed installations, heating coils are externally electroplated with tin.

Installation

Unscrew the insert **14** from the connection fitting **6** with the complete electrically insulated pipe screw joint (**4, 15, 16, 17, 18**), remove the cover **3**, carefully install the flange plate **19** (in so doing the ribs of the heat exchanger should not be bent when inserting it into the storage tank), place the flange seal in the plastic support disk and press it into position in the flange with 8 M12 x 35 screws, and/or 8 M12 nuts for flanges with $\varnothing = 180$ (RWT 1-110) or else with 12 M12 x 35 screws and/or M12 nuts for flanges with $\varnothing = 240$ (RWT 2-230, -360, -450). Tighten diagonally to a maximum torque of 3.5 mkp.

Caution: When tightening the screws and/or nuts the protective current bleeder resistor **1** attached to the brass tab **11** must not be damaged.

Fit the soft foam disc **13** (thermal insulation) and the lacquered cover **3** (for insulation purposes both plastic sleeves **2** must be mounted in the cover **3**). Seal in the inlay **14** with the cap nut **17** and the mounted insulating clip **15** and screw it onto the connection fitting **6** till flush with the plastic sleeve **2** and insert the insulating sleeves **4** into the inlay **14** and the connection nipple **18**.

Construct the heating circuit inflow plumbing and seal it at the connecting nipple **18**. Screw the cap nut **17** to the connection nipple **18**. The hexagonal surface on the connection nipple **18** is for holding with a spanner to counter the screw fastening motion. Maximum torque = 1.5 mkp.

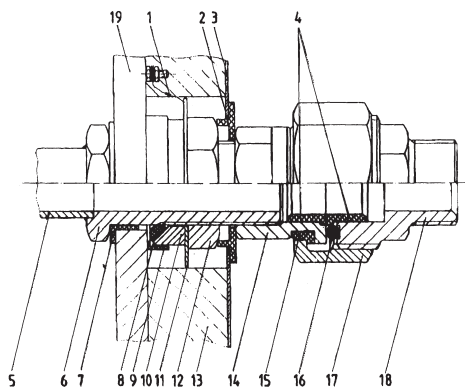

1 Resistance 620 Ω
 2 Plastic Insulator
 3 Cover
 4 Insulating Sleeve
 5 Heat Exchanger

6 Connection Fitting
 7 Insulating Sleeve
 8 O-Ring
 9 Plastic Bracket
 10 Swash Plate

11 Brass Bar
 12 Hexagonal Nut
 13 Foam Disc
 14 Insert
 15 Insulating Clip

16 O-Ring
 17 Cap Nut
 18 Connecting Nipple
 19 Flange Plate

Servicing

In the case of extremely hard water, the removal of the boiler scale accumulating in the storage tank's inner boiler must be performed by a professional after one or two years of operation. Cleaning is achieved by removing the ribbed pipe heat exchanger so that the lime-scale covered can be carefully chipped off or else cleaned in a container of boiler scale solvent.

Finally the heater exchanger must be rinsed thoroughly.

This device is not designed to be operated by people (including children) with limited physical, sensory or mental capacities or who lack the requisite experience and/or knowledge, unless they are supervised by a person responsible for their safety or have been instructed in the operation of the device by him/her. Children should be supervised in order to ensure that they do not play with the device.

Warranty, Guarantee and Product Liability

The warranty is granted in accordance with the statutory provisions of the Republic of Austria, as well as of the EU.

1. A condition for the operation of guarantee services by the product manufacturer (hereinafter referred to as the PM) is the presentation of the paid invoice for the purchase of the device for which the guarantee service is being invoked, whereby the identity of the device in terms of type and serial number must be taken from the invoice and must be produced by the claimant. This is subject exclusively to the PM's general terms and conditions of business and sales and delivery conditions.
2. To the extent required by law and/or the installation and operating instructions, the assembly, installation, connection and commissioning of the device in question must have been carried out by a licensed electrician and/or installer with due regard to the necessary instructions for this. The storage tank (without external covering or plastic external covering) must be protected from direct sunlight in order to prevent discolouring of the polyurethane foam and any possible warping of plastic components.
3. The room in which the equipment is operated must be free of frost. The assembly of the equipment must be carried out at a location which can be reasonably expected i.e. the equipment must be easily accessible and replaceable in the event of necessary maintenance, repair and possible replacement. The costs for any necessary changes to the structural conditions (e.g. doors and corridors too narrow) are not covered by the guarantee and warranty offered and shall therefore be refused by the PM. When setting up, installing and operating the water heater in unusual places (e.g. lofts, living quarters with water sensitive flooring, store rooms etc.) potential water leakage must be taken into consideration and therefore a device for capturing and draining off any leaked water must be provided in order to prevent secondary damage in the sense of the product liability provisions.
4. The warranty shall not apply in the following cases:
Improper transportation, normal wear and tear, deliberate damage or damage through negligence, any application of force whatsoever, mechanical damage or damage due to frost or resulting from exceeding the operational pressure stated on the rating plate even once, the use of connection fittings that do not comply with the applicable standards or non-functioning storage tank connection fittings, as well as unsuitable and non-functioning operating fittings, glass or plastic part breakage, any colour differences, damage through improper use, particularly by failing to observe the operating and assembly instructions (operating and installation instructions), damage caused by external influences, connection to the wrong voltage, corrosion damage due to aggressive waters not suitable as drinking water in accordance with national guidelines (such as the Austrian Drinking Water Ordinance TWV – BGBl. II no. 304/2001), Deviations of up to 10 K in the stated hot water temperature compared to the actual drinking water temperature from the storage tank (hysteresis of the regulator and possible cooling as a result of pipelines), continued use in spite of a defect, unauthorised modifications to the device, installation of additional components which have not been tested with the device, improperly performed repairs, insufficient conductance of the water (at least 150 µS/cm), operational wear and tear of the magnesium anode (consumable part), natural limestone formation, water deficiency, fire, flood, flooding, lightning strike, excess voltage, power failure and other force majeure, use of non-original and third party components, e.g. heating rod, protective anode, thermostat, thermometer, finned tube heat exchanger etc. components installed in a way that is non-insulated with regard to the storage tank, influx of foreign material and electrochemical installations (e.g. mixing installations), non-observance of the planning documents, late and non-documented renewal of the installed protective anode, faulty installation and connection of the external current anode (e.g., no permanent power supply), lack or improper cleaning and operation as well as deviations from the standard, which only slightly impair the value or the functionality of the device. Furthermore, the original installation at the place of assembly may not be altered or retrofitted before an inspection by the manufacturer or a commissioned expert. Any changes to the original installation on site will result in the immediate exclusion of all possible claims from the warranty or guarantee as well as product liability claims. In addition, as a matter of basic principle, all regulations set out in ÖNORM B 2531, DIN 1988 (EN 806), DIN 1717, VDI 2035 or the corresponding national regulations and legislation must be complied with.
5. In case of a justifiable claim, this must be reported to the nearest PM customer services centre. They shall reserve the right to decide whether a faulty component should be replaced or repaired and/or whether a faulty device will be exchanged for a fault-free device of the same value. In addition the PM expressly reserves the right to demand that the customer return the device to which the claim applies. The date of a repair or an exchange will be defined by the producer within 5 days!
6. Repairs under the guarantee may only be carried out by people licensed to do so by the PM. Exchanged parts shall become the property of PM. Should any repairs to the water heater be required following necessary service works these shall be invoiced to the customer as repair and pro-rata materials costs.
7. All warranty claims shall expire in the event of unauthorised third party interventions, even if these are carried out by a licensed installer. The acceptance of costs arising from repairs carried out by third-parties shall be subject to the PM having been requested to fix the fault and having either failed to meet their exchange or repair obligations or not having done so within a reasonable period.
8. The guarantee period shall neither be renewed nor extended as a result of the services in response to claims under the guarantee or warranty, or service and maintenance work.
9. Transport damage shall only be inspected and perhaps recognised if these are reported to the PM in writing within one working day of delivery.
10. To the extent permissible by law, any claims over and above provisions made in the guarantee, such as in particular those relating to compensation for damages and consequential losses, are excluded. Pro-rata labour hours for repairs, as well as the costs of restoring the system to its original condition must be paid by the customer at the full rate. The guarantee offered shall only cover the repair or replacement of this device in accordance with this guarantee statement. The provisions of the PM's sales and delivery conditions shall continue to apply in full provided that they are not modified through these guarantee conditions.

RIBBED PIPE HEAT EXCHANGER RWT

11. Services not provided within the framework of these guarantee conditions shall be invoiced to the customer.
12. A precondition for the fulfilment of these guarantee provisions by the PM is that, on the one hand the device has been fully paid for and, on the other hand, that the claimant has fully complied with all of his obligations towards the reseller.
13. A guarantee shall be provided for the enamelled internal boiler for water heaters, with no diminution of the guarantee provisions in accordance with Points 1 to 12 for the period offered following delivery. If the guarantee conditions are not met then the legal warranty conditions of the country to which the goods have been delivered shall apply.
14. For the attainment of claims in accordance with Austrian product liability legislation, it should be noted that:
Any possible claims from the product liability stated above which deal with damage caused by a failure of a product (e.g. a person receives bodily injury, health is damaged or some other bodily part is damaged by the product), are only justified when all the prescribed measures and requirements which are needed for error-free and standard compliant operation of the device have been fulfilled. This includes for example the mandatory and documented replacement of the anode, connection to the correct operating voltage, damages arising from improper operation are to be avoided etc. These provisions are to be derived from the fact that, had all instructions been complied with (standards, installation and operating instructions, general guidelines etc.) the fault in the device or product that caused the secondary damages would not have arisen. Furthermore, it is indispensable that the necessary documentation, such as for example the designation and manufacturer number of the storage tank, the seller's invoice and the concessionaire who performed the sale as well as a description of the fault are submitted for the inspection of the allegedly faulty storage tank in the technical laboratory (absolutely necessary as a trained professional will inspect the storage tank and analyse the cause of the fault). To avoid any confusion regarding the storage tank during transportation, it must be provided with a clearly legible label (preferably with the address and signature of the end user). Furthermore, the original installation at the place of assembly may not be changed, converted or dismantled before being inspected by the manufacturer or an appointed expert.
Any change to the original assembly situation on-site will lead to the immediate exclusion of any claims arising from the warranty, guarantee or product liability.
A corresponding photographic record is required showing the extent of the damage, the installation details (cold water input, hot water output, heater flow and/or back-flow, safety fittings, and, if applicable, expansion vessel) as well as the faulty area of the storage tank. In addition the PM expressly reserves the right to demand the provision of any documentation, the device or device components by the customer deemed necessary to clarify the situation. A prerequisite for the performance of services under the heading, Product Liability, is that it is incumbent upon the damaged party to prove that the damage was caused by a product of the PM. Claims made in line with the Austrian Product Liability Act are only valid for the sums above the first EUR 500 (excess). Until such time as the entire situation and circumstances have been clarified as well as until such time as the cause that resulted in the damages has been clearly identified, the PM decidedly rejects any potential culpability. Failure to follow the operating and assembly instructions as well as the relevant standards is considered negligence and shall leads to a liability exclusion in the field of compensation for damage.

The figures and data are not binding and may be amended without notice in the interest of technical improvement.
Misprints and technical changes reserved.

Notes



Austria Email

Austria Email AG

Austriastraße 6

A-8720 Knittelfeld

Telefon: (03512) 700-0

Fax: (03512) 700-239

Internet: www.austria-email.at

E-Mail: office@austria-email.at

Austria Email in your area?

For addresses and telephone numbers of our subsidiaries,
visit our homepage at **www.austria-email.at**

Print errors and changes of all kinds are reserved.
Reproduction prohibited.