

ANG

Instructions for Use and Installation

Domestic Hot Water Heat Pump

WPA 303 E-LF

These instructions must be handed over
to the end user.



AE
Austria Email

Instructions for Use and Installation. - Version 1.0 - 01/2021

Printed in Austria, Copyright by Austria Email AG

This text is protected by copyright. Any use outside limits of the copyright act without the consent of Austria Email AG is illegal and punishable by law. With this all previous version are invalid. We reserve the right to change the text.

1 Table of Contents

1	Table of Contents	2
2	Introduction.....	4
2.1	Symbols.....	4
2.2	General	5
2.2.1	Obligation of the Manufacturer.....	5
2.2.2	Customer Support - Service	5
2.2.3	Obligation of the Installer	5
2.2.4	Obligation of the User.....	6
2.3	Conformity.....	6
2.3.1	Directives	6
2.3.2	Standards	6
2.3.3	Factory Testing.....	6
3	Safety Advice and Recommendations.....	7
3.1	Safety Advice	7
3.2	Recommendations.....	7
3.3	Safety Data Sheet: Refrigerant R134a	8
3.3.1	Identification.....	8
3.3.2	Potential Dangers.....	8
3.3.3	Composition	8
3.3.4	First Aid	8
3.3.5	Fire-Fighting Measures	8
3.3.6	In Case of Leakage.....	9
3.3.7	Handling	9
3.3.8	Personal Protective Equipment	9
3.3.9	Recycling/Waste Management.....	9
3.3.10	Directives	10
4	Technical Description	10
4.1	General	10
4.2	Component Parts.....	12
4.3	Operating Principle.....	13
4.4	Technical Data	15
5	Installation.....	16
5.1	Scope of Delivery	16
5.2	Storage.....	16
5.3	Transport	16
5.4	Place of Installation	16

5.5	Installation	18
5.5.1	Hydraulic Connection.....	18
5.5.2	Connection of the Air Duct System.....	19
5.5.3	Connection of Condensate Discharge.....	20
5.5.4	Connection of the Secondary Source.....	22
5.5.5	Electrical Connection	24
6	Heat Pump Start-up.....	25
6.1	Filling the System with Water.....	25
6.2	Control prior to Start-up.....	25
6.3	Connection of the Heat Pump to the Power Network	25
6.4	Start-up	26
6.5	Heat Pump Operation.....	26
6.6	Settings	27
7	Dismantling and Removal.....	30
8	Maintenance	30
8.1	General	30
8.2	Care and Maintenance	31
8.2.1	Care	31
8.2.2	Maintenance	31
9	Disturbances in the Functioning.....	31
9.1	Warning signs	31
9.2	Error Indication.....	32
10	Warranty, Guarantee and Product Liability.....	33

2 Introduction

First, we would like to thank you for your trust, which you showed by purchasing our product and we firmly believe that the appliance will serve you well. Prior to initial use, carefully read the contents of the following instructions for safe usage and maintenance and familiarize yourself with the purpose, functionality and methods of handling with the appliance. The instructions are composed so as to assure that you are well acquainted with all the necessary actions prior to the initial as well as each subsequent use. But still, have your licensed installer explain to you the functioning of the device and demonstrate its operation. Of course, our company is also glad to be at your disposal through the Customer Services and Sales Departments for any advice you may require.

If you intend to hand over this product to a third person, make sure that you will also enclose the instructions for safe use and maintenance.

2.1 Symbols

During installation, maintenance works and usage different levels of danger may occur. Certain chapters and paragraphs contain warning sentences, which are intended to provide the user's safety, eliminate possible dangers and ensure a correct operation of the appliance. Please, pay particular attention to these chapters.



DANGER

Risk of a situation with possible occurrence of heavy personal injuries.



WARNING

Risk of a situation with possible occurrence of light personal injuries.



WARNING

Risk of device damage.



CAUTION

Instructions for use and installation must be read.



DANGER

Danger electricity.



NOTE

Important information.

2.2 General

2.2.1 Obligation of the Manufacturer

Our products are consistent with all current European directives and standards. They are labelled with the CE sign and have all the necessary documentation.

For the interests of the customers, improvements on the quality and product safety are constantly being carried out; therefore all specifications set out in this document may be altered without prior notice.

As a manufacturer, we cannot assume responsibility in the following cases:

- Disregard of the instructions for use.
- False and/or insufficient maintenance of the appliance.
- Disregard of the installation instructions.

2.2.2 Customer Support - Service

Customer support and service during warranty period is guaranteed by Austria Email AG.



When ordering spare parts for this device, please provide the following:

- product
- exact title of the product
- serial number
- production year

All necessary information can be obtained from the identification label located on the appliance.



NOTE

Any modifications or replacements of parts other than original or any forced or incorrect use of the appliance shall cease the manufacturer's guarantee. Any possible costs resulting from a servicing procedure shall be settled solely by the user.

2.2.3 Obligation of the Installer

The installer is responsible for a correct installation and start-up of the appliance, according to the following requirements:

- The enclosed instructions for installation and use must be read thoroughly.
- Installation of the appliance must be carried out in compliance with the current national legislation, regulations and standards.
- Implementation of the start-up and elimination of any irregularities detected at the start-up.

- Explanation of the entire system's operation.
- The fitter must remind the user to carry out regular maintenance works on the appliance to ensure its proper functioning throughout the entire life-span.
- All maintenance works must be written down in a service record at the end of this instruction manual.
- All documentation enclosed to the appliance must be handed over to the end user.

2.2.4 Obligation of the User

In order to ensure undisturbed and efficient operation of the appliance, the user must consider the following instructions:

- Thoroughly read the enclosed instructions for safe use and installation.
- Installation and start-up of the appliance must be performed by an authorised and technically qualified person.
- Ask the authorised installer to explain in detail the functioning of the appliance and how it is managed.
- Ensure that the appliance is regularly inspected and maintained by an authorised and qualified after-sales service technician.
- Keep these instructions for use and maintenance in a suitable dry place near the appliance.

2.3 Conformity

The CE sign confirms that the appliance is manufactured in compliance with the currently valid directives and standards.

2.3.1 Directives

- **DIRECTIVE 2006/95/EC** OF THE EUROPEAN PARLIAMENT AND OF THE COUNCIL of 12 December 2006 on the harmonisation of the laws of Member States relating to electrical equipment designed for use within certain voltage limits
- **DIRECTIVE 2006/42/EC** OF THE EUROPEAN PARLIAMENT AND OF THE COUNCIL of 17 May 2006 on machinery, and amending Directive 95/16/EC
- **DIRECTIVE 97/23/EC** OF THE EUROPEAN PARLIAMENT AND OF THE COUNCIL of 29 May 1997 on the approximation of the laws of the Member States concerning pressure
- **DIRECTIVE 2004/108/EC** OF THE EUROPEAN PARLIAMENT AND OF THE COUNCIL of 15 December 2004 on the approximation of the laws of the Member States relating to electromagnetic compatibility and repealing Directive 89/336/EEC

2.3.2 Standards

- EN 60335-1:2012
- EN 60335- 2-21
- EN 60335-2-40
- EN 50417
- EN 60730-1
- EN 61000-3-2:2006

2.3.3 Factory Testing

In order to ensure high quality of each heat pump before it is sold, the following tests are carried out:

- tightness of the refrigeration circuit







- water-tightness
- air-tightness
- electrical safety
- functionality

3 Safety Advice and Recommendations

3.1 Safety Advice

The appliance is manufactured in accordance with the current directives and standards, which enables the manufacturer to label the product with the CE sign. In order to maintain safety and functionality of the appliance, there are warning signs and symbols – pictograms – on the device to warn the user of potential dangers.

Explanation of warning signs (pictograms) on the device:

		
		
Read the Instructions for use and instalation	Danger of electric shock	The device must not be layed down. Must stay in vertical position during transport and operation.

3.2 Recommendations

Persons, especially children, who are not capable of operating the device safely due to their physical, sensory or mental abilities or their inexperience or lack of knowledge, must not operate this device without supervision or instruction by the person in charge. Children must be supervised to ensure that they do not play with the device. During operation the device must not be moved, cleaned or mended. Before installation and any further work on the device, it is necessary to read the contents of the instructions for safe use and maintenance.

Electrical connection must be carried out by a qualified person and it is necessary to disconnect all electrical circuits from the power source prior to opening the device. The connection cable must be accessible and it must be easy to pull the plug from the socket. It is forbidden to place any kind of objects around or on top of the device. Free access to the appliance must be provided at all times. There must be at least 1 m of space in front of the device and on both sides, so that the heat pump is easily accessible if any work on the device is needed. If during operation the temperature of the water exceeds 75°C, you must contact an authorised service technician. Ensure that the device is not a threat to anyone and that children and not-qualified persons do not have access to the device.

3.3 Safety Data Sheet: Refrigerant R134a

3.3.1 Identification

The working fluid in the appliance is hydro fluorocarbon (HFC) 134a. The refrigerant is not toxic, flammable or explosive and is also not harmful for the ozone, but is however heavier than air, which can cause displacement of air from a room. This may result in a lower concentration of oxygen in the air; however, due to an extremely small quantity of the refrigerant in the device, serious risks for health are excluded. A reduced concentration of oxygen can only occur in spaces smaller than 10 m³, with no ventilation and located below ground, where the refrigerant, which is heavier than air, can remain present for a longer period of time. Nevertheless, we recommend that you read the safety data sheet of the refrigerant manufacturer and act in accordance with the written guidelines.

3.3.2 Potential Dangers



DANGER

Risk of a situation with possible occurrence of heavy personal injuries.

1. Danger of health risks:
 - Refrigerant vapours are heavier than air. Refrigerant can cause displacement of air from a room. As a consequence, dizziness, loss of consciousness, or even suffocation may occur.
 - Liquefied gas: Contact with the liquid may cause serious frostbite and damage to the eyes.
2. Product classification: This refrigerant is not labelled as »harmful/hazardous to health« product in accordance with the EU regulation.

3.3.3 Composition

1. Chemical composition: R – 134a C₂H₂F₄ – Tetrafluoroethane

Name of the composition	Concentration	CAS number	CE number	GWP
1, 1, 1, 2 – Tetrafluoroetan R-134a	100%	811-97-2	212-377-0	1300

3.3.4 First Aid



NOTE

Important information.

1. When inhaling: Remove the person from the contaminated room to the open air. If the person is not feeling well, you must bring that person to the doctor.
2. In case of skin contact: Frostbites are treated the same as burns. Rinse well with clean water and do not remove the clothes (risk that the clothes adhere to skin). If skin burns occur, call the doctor immediately.
3. In case of eye contact: Immediately rinse with clean water, while keeping the eyes constantly open (at least 15 min).
Consult an eye doctor.

3.3.5 Fire-Fighting Measures

1. Appropriate extinguishing agents: The use of fire extinguishing agents is limited according to space and circumstances in which the fire is being extinguished. The refrigerant does not limit any extinguishing agent.
2. Inappropriate extinguishing agents: not recommended. In case of a fire, use an appropriate extinguishing agent.
3. Special dangers:
 - Increased pressure. If air (oxygen) is present, certain temperature and pressure conditions may cause formation of flammable substances.
 - In case of high temperatures (above 200°C), toxic and corrosive gases may start to leak out.
4. Special intervention methods: use the fire extinguisher to cool off that part of the device or the refrigerant, which is exposed to heat.
5. Protection of fire-fighters:
 - Fully closed mask with an oxygen snorkel.
 - Protection of the entire body.

3.3.6 In Case of Leakage

1. Special safety measures:
 - Avoid contact with skin and eyes – danger of frostbites.
 - Do not intervene without personal protective equipment.
 - Do not inhale vapours – danger of suffocation due to low concentrations of oxygen in the air.
 - Evacuate the danger area.
 - Stop the leakage.
 - Remove all potential sources of ignition, heat.
 - The room, in which the leakage of the refrigerant occurred, must be ventilated well (danger of suffocation).
2. Cleaning/decontamination: let the refrigerant to evaporate.

3.3.7 Handling

1. Technical measures: In case of leakage, ventilation is necessary.
2. Precautionary measures:
 - Smoking not allowed.
 - Prevent accumulation of electrostatic charge.
 - In case of maintenance and service works, the room should be well ventilated.

3.3.8 Personal Protective Equipment

1. Respiratory protection:
 - In case of insufficient ventilation: protective mask of AX type.
 - In closed spaces: fully closed mask with oxygen snorkel.
2. Hand protection: protective gloves made of nitrile rubber or leather.
3. Eye protection: protective goggles with side shields.
4. Skin protection: clothes made primarily of cotton.
5. Industrial hygiene: eating, drinking and smoking in the workplace is not allowed.

3.3.9 Recycling/Waste Management

1. Product waste: consult the product manufacturer on recycling or processing.
2. Dirty packaging: re-use or recycling after decontamination. To be destroyed in facilities intended for this purpose.

**ATTENTION**

Disposal must be performed in accordance with the local and national provisions.

3.3.10 Directives

Disposal of the refrigerant must be carried out in accordance with Directive 842/2006/EC, as well as other national and local regulations.

4 Technical Description

4.1 General

This device is a heat pump used for domestic hot water (DHW) heating in residential or small office buildings where daily consumption of hot water does not exceed 500 litres (WPA 230 ECO) / 700 litres (WPA 302 ECO). While heating tap water, the heat pump simultaneously cools down the area where it is installed or from which the air is taken. In addition to tap water heating, the heat pump may also be used to cool down a selected room (e.g. cellar, storage room, etc.), but it needs to be stressed, that the cooling will only take place simultaneously with tap water heating. If there is no need for tap water heating, the cooling will also not be carried out.

To achieve high efficiency and savings it is recommended to use air from rooms with waste heat (boiler rooms, laundries, kitchens, basements, storage rooms, etc.) as a heat source.

Dimensions:

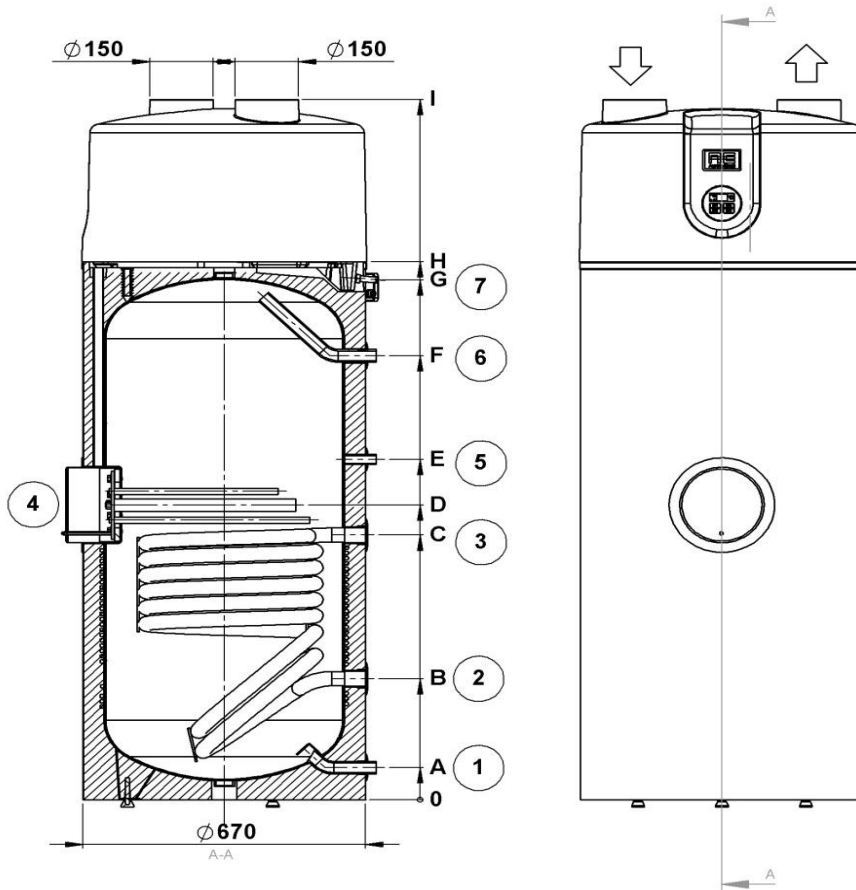

WPA 303 E-LF	
A [mm]	85
B [mm]	320
C [mm]	700
D [mm]	780
E [mm]	900
F [mm]	1175
G [mm]	1375
H [mm]	1422
I [mm]	1853
1	Cold water connection 1"
2	Heating water connection 1" – return flow
3	Heating water connection 1" – outlet flow
4	Flange
5	Recirculation connection 3/4"
6	Hot water connection 1"
7	Cndensate connection – Ø16

4.2 Component Parts

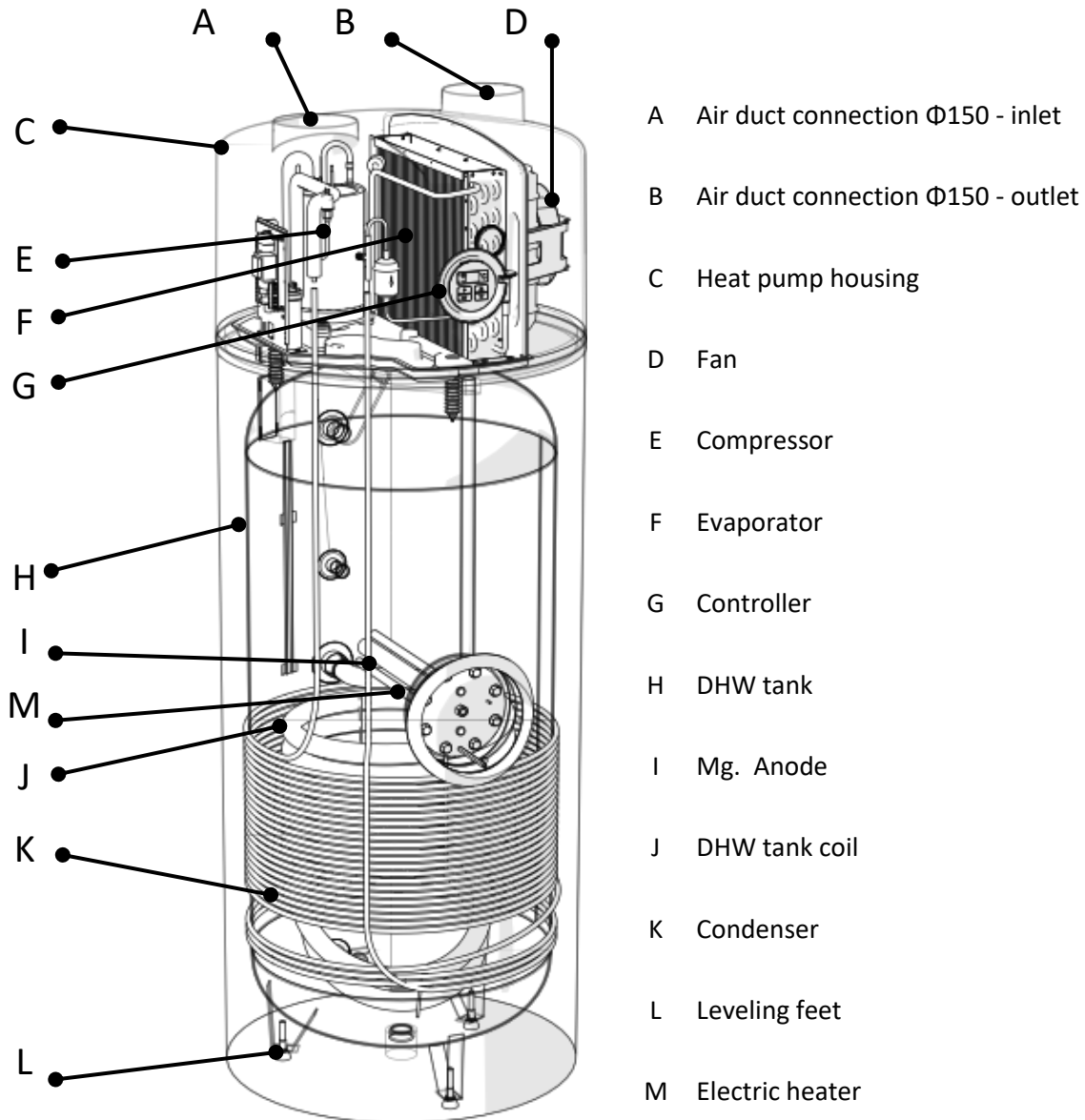

DHW heating by means of a heat pump is a very efficient way of hot water supply. A heat pump consists of a heat pump unit (compressor, evaporator, fan, etc.) and a water heater. The housing of the unit is made of a resistant EPP material with thermal and sound insulation. The device has two connections for air ducts, which enables the supply and discharge of air from an adjoining room or from the outside. The water heater is equipped with an additional heat exchanger for the connection of a fossil-fuel boiler, biomass boiler or solar panels.

4.3 Operating Principle

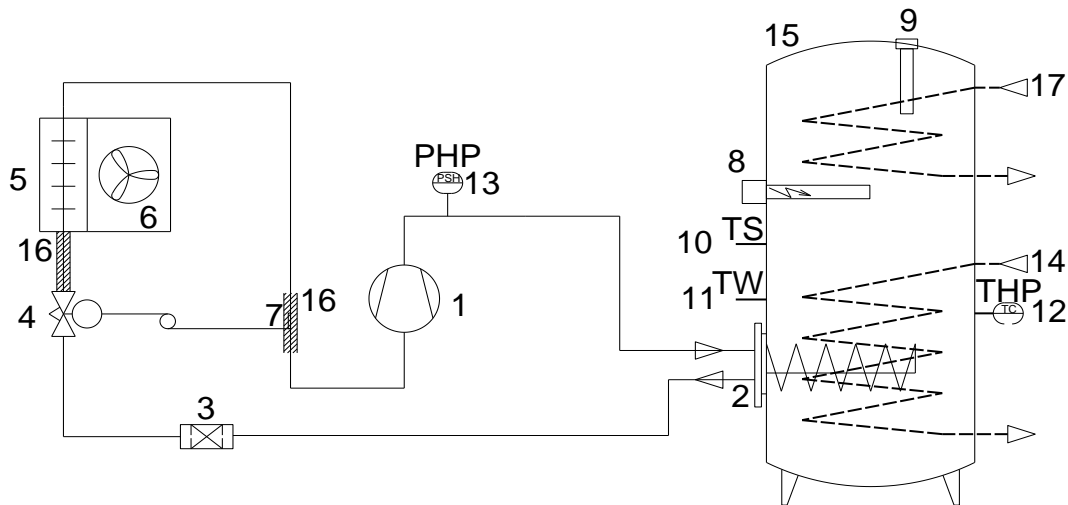

1. Compressor
2. Condenser
3. Filter dryer
4. Expansion valve
5. Evaporator
6. Fan
7. Expansion valve sensor
8. El. heater
9. Mg. anode
10. /
11. El. heater –safety thermostat
12. Sensor – heat pump
13. High pressure switch
14. Heat exchanger – heating water
15. Water heater
16. Thermal insulation

The refrigerant circuit in a heat pump is a closed system in which the cooling agent R 134a is circulating as the energy carrier. When the pressure and the temperature are low (e.g. 20°C) the refrigerant is evaporated in the heat pump evaporator and the heat is extracted from the air. In the compressor the refrigerant is then compressed to a higher level, which causes the temperature of the refrigerant to rise above the temperature of the water in the water tank. Next, the refrigerant transfers the heat to the water and is then liquefied. With the expansion of the refrigerant, whereby the pressure and temperature of the refrigerant are reduced to the initial value, the cycle is concluded. This process is continuously repeated during the heat pump's operation.

Water Heater (hot water tank)

The water heater is enamelled on the inside with a patented technology, thermally insulated on the outside with polyurethane and mechanically protected with steel plate. The water heater contains a heat exchanger as standard equipment for connection to the boiler if bivalent operation of the heat pump is selected. The water heater is also fitted with a protective Mg-anode, which prevents corrosion of the water heater in the event of a mechanical damage to the enamel. Three levelling feet are enclosed, which enable the placement of the device on an uneven base. For a correct placement of the heat pump, please use a spirit level.

Additional Electric Heater

An additional electric heater with 1.5 kW of power serves to:

- **heat the water quickly;** the heat pump and the electric heater operate at the same time,

- **protect the evaporator from frosting;** if in summertime the heat pump cannot operate due to a low room temperature, the EH switches on,
- **alternative source;** in case of a failure of the heat pump unit.

Frost protection sensor

The heat pump regulator contains an air temperature sensor, which measures the temperature of the air that flows through the evaporator. If the air temperature is below 7°C (factory-set), the sensor switches off the HP for at least 30 minutes. If the heat pump has an integrated electric heater, the heating is automatically reconnected using the electric heater (in summertime), or the circulation pump of the connected boiler is switched on (in wintertime).

Safety thermostat of the electric heater

The electric heater has an integrated working and safety thermostat limited to 65 °C. The safety thermostat switches off at 85 °C and must then be reset manually.

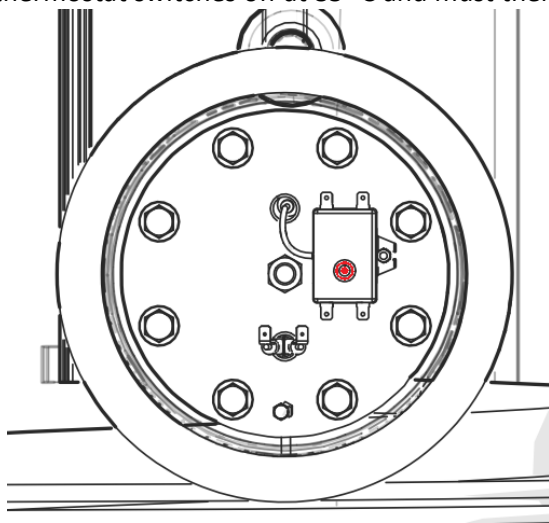

The safety thermostat is below the flange cover

Unplug the heat pump from the power supply:

- Remove the flange cover.
- Press the red button on the safety thermostat until you hear a „Click“.
- Mount the flange cover.

Control of the water temperature in the water heater

The OPTITRONIC regulation is used to monitor the heating of water to the set temperature. Depending on the set water temperature, the regulation starts or stops the operation of the compressor and the fan and under certain conditions it also switches on and off the electric heater or the boiler circulation pump. The maximum set heating temperature is 55°C when operating with the compressor. When using the “HT” key for fast heating, the temperature reaches 60°C.

High pressure control

A high-pressure safety switch is installed to prevent the occurrence of high pressure in the refrigerant circuit and possible damages. In the event of an increased pressure, the heat pump operation is switched off, thus preventing damage to the compressor. If the pressure in the system drops, the heat pump automatically switches back on. In this case error »E7« appears on the display.

Operating conditions

In normal operation, the ambient temperature should be between -7°C and +35°C. The air must be clean and the relative humidity at +40°C should not exceed 50%. If the ambient temperature is lower, the relative air humidity can be somewhat higher. The appliance cannot be installed at a height of more than 2000 m above sea level, since the lower air pressure can substantially reduce the heating capacity of the device.

ATTENTION

The heat pump must never be installed in locations, where there may be harmful substances present in the air, which could damage the device (stables, storage rooms for hazardous substances, outdoors, etc.).

4.4 Technical Data

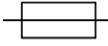
Product	Heat pump for DHW heating with air duct.	
	WPA	
Type		
Model	WPA 303 E-LF	WPA 233 E-LF
Heating capacity:	1830 W (3330 W)*	
Power consumption:	440 W (1940 W)*	
Max. power consumption:	560 W (60°C) (2060 W)*	
El. heater:	1500 W	
Voltage:	230 V a.c.	
Max. additional power for circ. pump:	300 W	
COPt (EN16147; A15W55; XL)	3,0	2,9
Refrigerant:	R134a (0,9kg)	
Max. water temperature:	60°C - 65°C (75°C)*	
Required air flow rate:	500 m ³ /h	
Protection class:	IPX1	
Ambient air temperature:	+7 - +35°C	
Water heater protection:	Mg-anode	
Sound level:	56 dB(A)	
El. protection	 16 A, (230 V a.c.)	
Max. allowed pressure in the WH:	1,0 MPa (10 bar) at 95°C	
Max. allowed pressure in the heat exchanger (heating water):	1,0 MPa (10 bar) at 110°C	
Max. allowed pressure in the cooling circuit:	2,3 Mpa (23 bar)	
Heating capacity of the boiler heat exchanger:	15 kW	
Water connections:	G 1"	
Circulation:	G ¾"	
Air connections:	Φ 150 mm	
WH volume:	300 L	225 L
Mass	175 kg	130 kg
Minimum room height	2200 mm	2000 mm

* In case of an additional el. heater.

5 Installation

5.1 Scope of Delivery

Scope of delivery:

1. Heat pump WPA 230 ECO
2. Instructions for installation and use
3. Levelling feet

5.2 Storage

The appliance must be stored in a dry and clean place. The allowed storage temperature is between 10°C and 45°C, for a short period of time (up to 24 hrs) the temperature can reach up to 55°C.

5.3 Transport

During transportation, the heat pump is protected with protective foil and cardboard packaging to prevent damage such as indentations and scratches. If necessary, the heat pump can be additionally protected to avoid mechanical damages. After transportation, the device must be kept in the upright position for at least 2 hours so that the distributed oil collects again in the compressor.



CAUTION

The appliance is too heavy for manual transportation. Such transportation can lead to personal injuries and damages to the device. All responsibility for possible damages is assumed by the buyer.



CAUTION

Never place the heat pump in horizontal position.

5.4 Place of Installation

The heat pump should in no case be installed in a place, where there are harmful substances present in the air (stables, storage rooms for hazardous substances, outdoors, etc.). The minimum ceiling height must be at least 2100 mm and the minimum room size must be 20 m³. The construction of the device enables the heat pump to exploit the warmth of the ambient air or to supply the inlet air from the neighbouring rooms or from the outside via air duct system. The heat pump enables the following types of ventilation, depending on the design of the piping system:

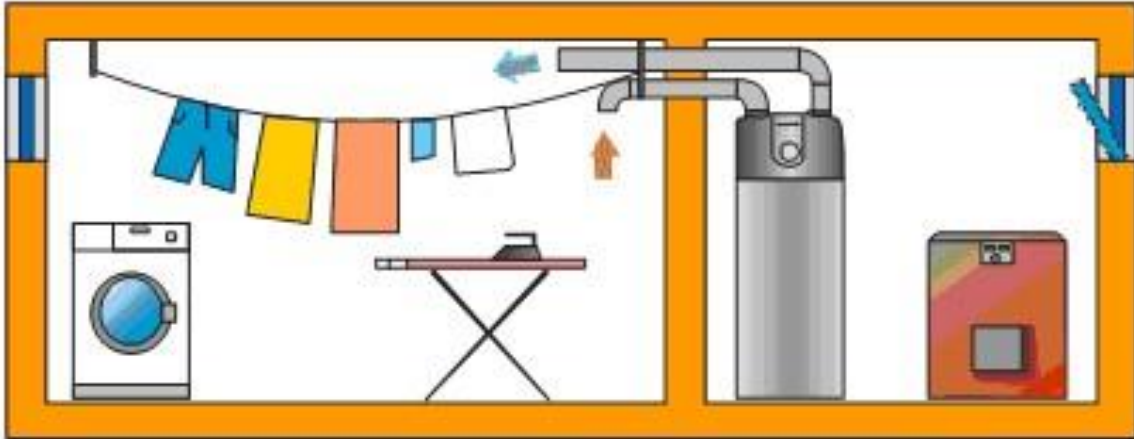

Figure 1: Air is supplied from a neighbouring room and discharged back into the same room. Drying of linen.

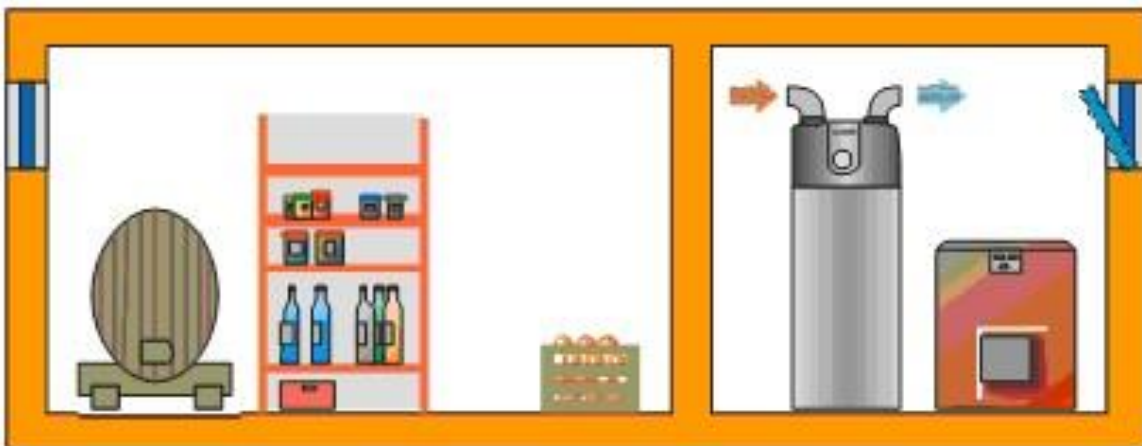

Figure 2: Air supply and discharge take place in the room where the HP is installed.

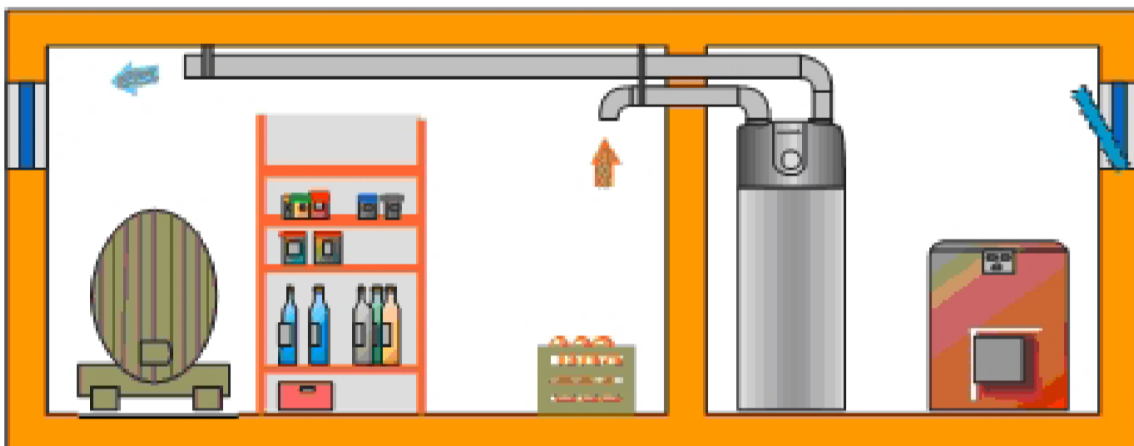

Figure 3: Air is supplied from a neighbouring room and discharged back. Cooling of a storage room.

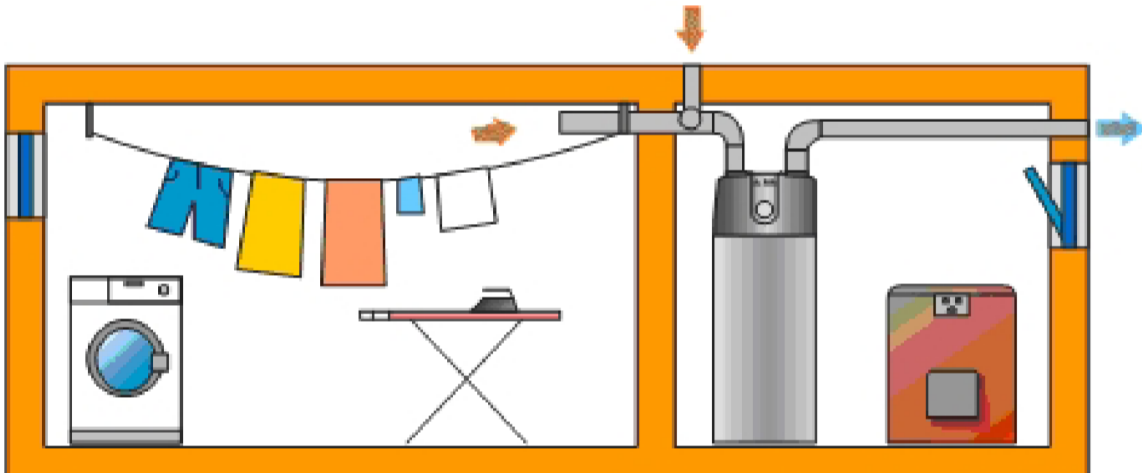

Figure 4: Air is supplied from a neighbouring room and discharged into the surroundings.

The most frequent air duct system is one, where the air is supplied from spaces with large quantities of waste heat. Heat is extracted from the air, which is then discharged into the surroundings. Air from kitchens, laundry rooms, bathrooms and toilets, etc. frequently contains odours and is therefore discharged into the surroundings.

5.5 Installation

5.5.1 Hydraulic Connection

Hydraulic connection must be carried out in accordance with the current national and local regulations which apply to the connection of water heaters. Figure below illustrates a correct hydraulic connection of the heat pump. The maximum pressure in the piping system must not exceed 6 bar. If the tube heat exchanger inside the water heater will not be used, it must be filled with a glycol mixture to avoid corrosion in the exchanger. The filled heat exchanger must not be closed air-tight at both ends (pressure equalization due to temperature changes).

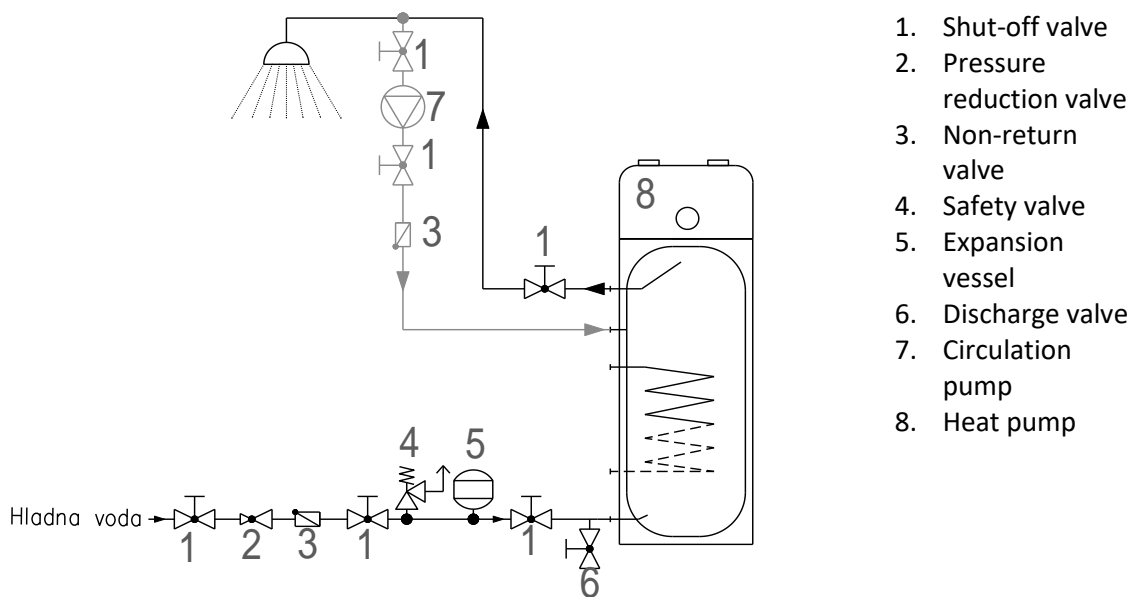

Expansion vessel dimensioning:

Safety valve setting [bar]	6			10		
System pressure [bar]	3,0	3,5	4,0	3,0	3,5	4,0
Water heater volume [L]	Expansion vessel [L]					
450	24	32	44	15	16	17

*This is only a recommendation. The exact size of the expansion vessel must be determined by the installer/project designer according to the size of the system to which the vessel will be installed.

5.5.2 Connection of the Air Duct System

A heat pump with air-duct system enables the following:

- placement in any room large enough for the installation of the device,
- ventilation of a selected room,
- discharge of waste air or supply of fresh air from the outside.

The air duct system should be executed in such a way, that it minimizes the change of the air flow direction. The distance between the point of air intake and the point of air discharge should not exceed 10 m. Frequent change of the air flow direction is regarded as additional air resistance, which means that the length must be shortened. Each additional 90° pipe elbow shortens the overall length by 0,5 m. Closure elements (grates, filters, ventilation valves, etc.) in the air duct system must be taken into account as well. Increased pressure drop in the duct system reduces the air flow. If the air temperature is below +10°C, this can cause a slow freezing of the evaporator and thus less efficient ventilation, which is difficult to notice.



NOTE

It is necessary to install at least one 90° pipe elbow in order to prevent the inlet and outlet air to mix.

Figure below illustrates the heat pump cover with nozzles for air ducts, which are 45 mm high with an external diameter of $\Phi 150$. Access to the internal parts is covered with a protective grid, which must not be removed.

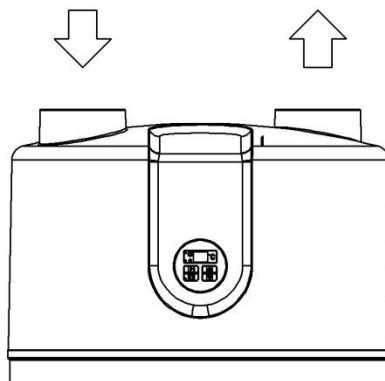

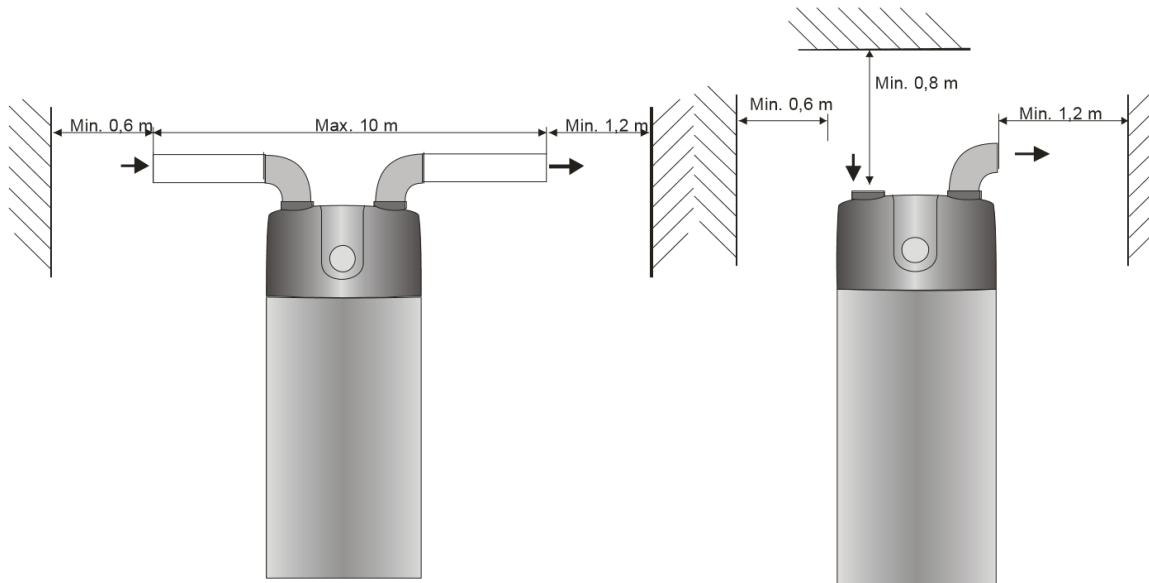

If the heat pump extracts heat from the surrounding air, the room size must be at least 30 m³.

Maximum length of the air ducts:

Maximum length of the air ducts	m
Inner diameter 150 mm	10 m
Inner diameter 160 mm	15 m
Inner diameter 200 mm	25 m

When determining the overall length of the air ducts, the equivalent length of the accessories, e.g. pipe elbows reduction pieces, etc.

Accessories	Equivalent length in m
Elbow 90° (Φ 160 mm)	3
Elbow 90° (Φ 200 mm)	2
Reduction piece Φ200xΦ160	1
Outer grating (Φ 160 mm)	2

5.5.3 Connection of Condensate Discharge

The extraction of heat from the air causes the condensation of air humidity in the heat pump. Depending on the season and hot water requirements, between 1 and 5 litres of condensate per day accumulate. This condensing water can be used for steam ironing or watering. A discharge tube is fitted at the back of the device to drain the condensate. If free drainage of the condensation is not possible, a collecting vessel of at least 10 litres must be provided.

Caution: when connecting condensate outlet care must be taken that the tube is always turned downwards. If longer tubes are used, a return valve must be fitted at the bottom of the outlet tube to ensure proper drainage of the condensate and to avoid the discharge odour to spread.

Condensate outlet tube must be connected to the device and routed to the sewage or collecting vessel.

At the end of the tube a siphon must be made to prevent suction of odours from the drain.

Routing of the condensate outlet pipe must always provide the water to freely drain from the device. It is recommended that the water is routed into a drain; however, if that is not possible, a collecting vessel must be provided, which must be regularly emptied.

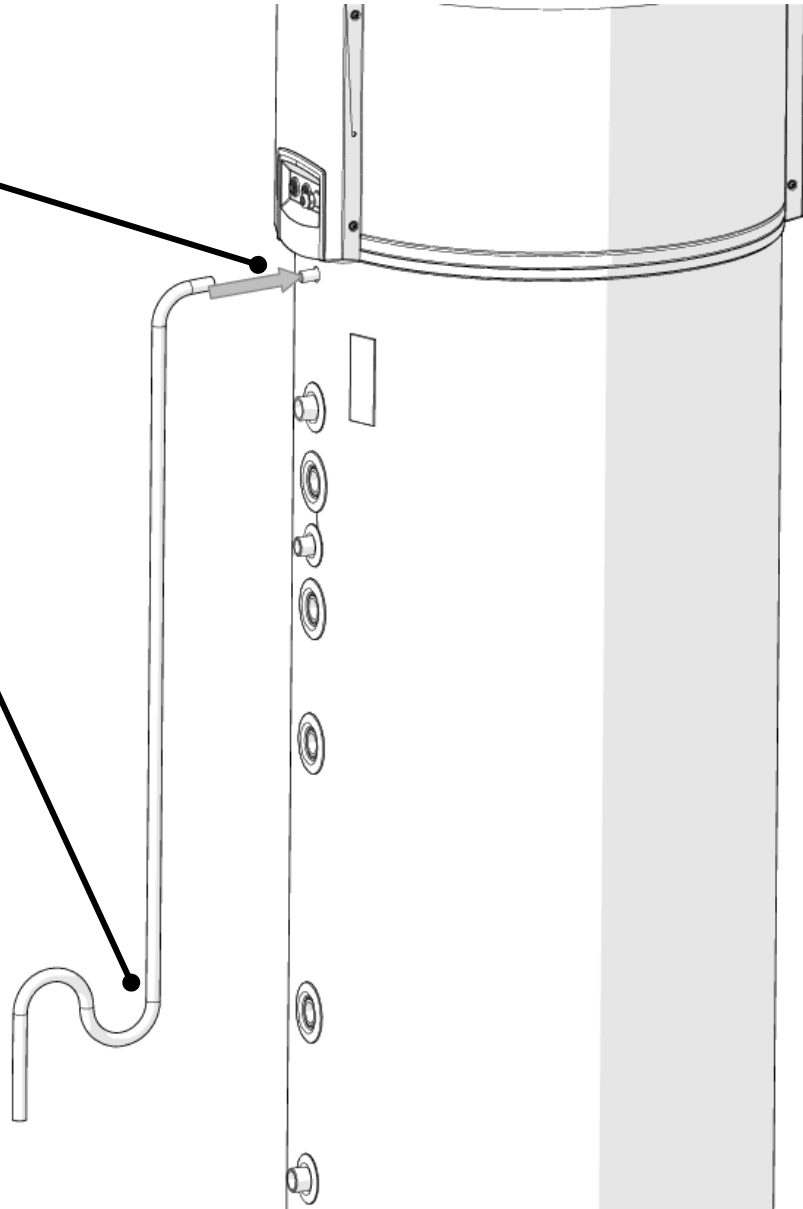

Levelling of the heat pump



ATTENTION

Instructions provided in the figures below must be taken into account to ensure a suitable outlet of the condensate water.

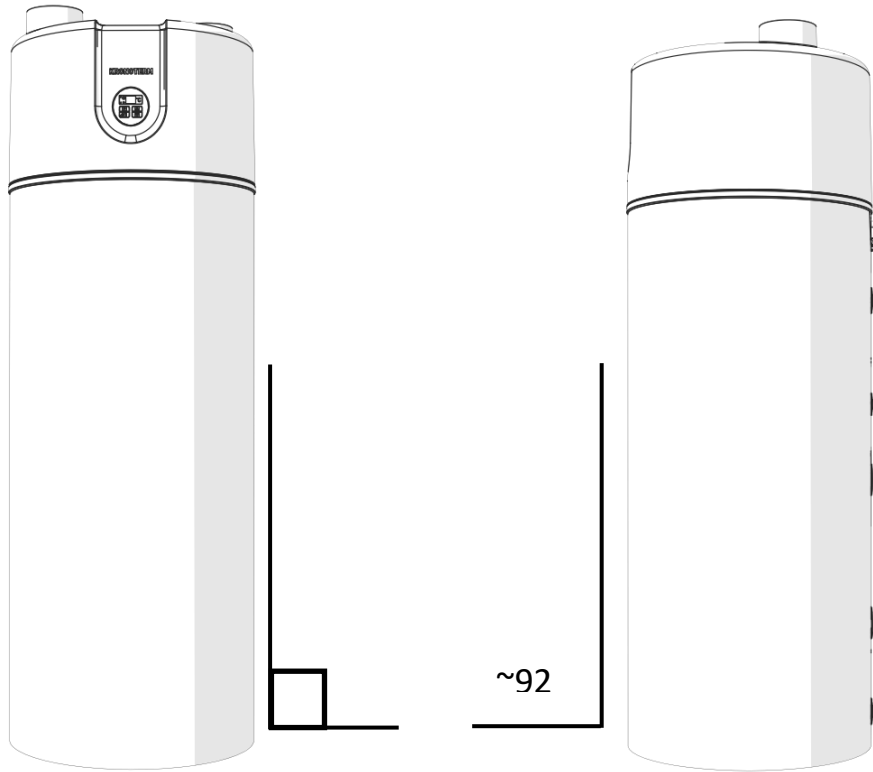

The heat pump must be leaned slightly backwards to ensure an appropriate outlet of the condensate.

5.5.4 Connection of the Secondary Source

Domestic hot water in the water heater can be heated in various ways with different heat generators. The primary heat generator is the heat pump; however, when the heat pump cannot operate on its own, it can be connected to the secondary heat generator – the boiler. The combination of a heat pump and a boiler is called bivalent operation, which during winter enables both, the central heating and DHW heating.

1. Shut-off valve
 2. Pressure reduction valve
 3. Non-return valve
 4. Safety valve
 5. Expansion vessel
 6. Filling valve
 7. Recirculation pump
 8. Heat pump
 9. DHW Tank
 10. Buffer Tank
 11. Solar heat collectors
- dT – diferencial thermostat

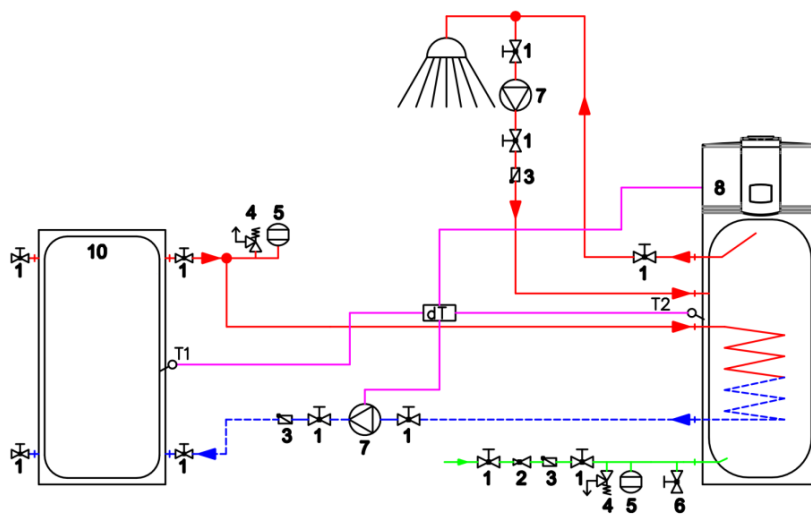
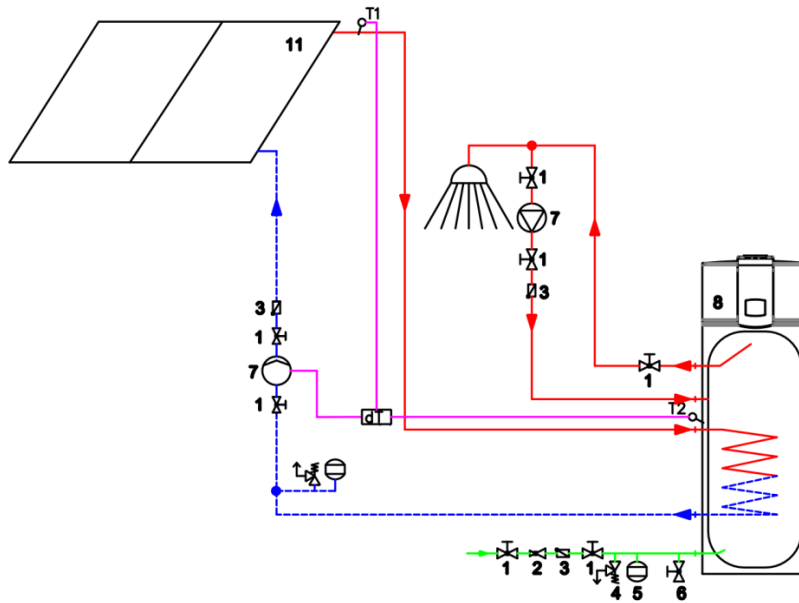
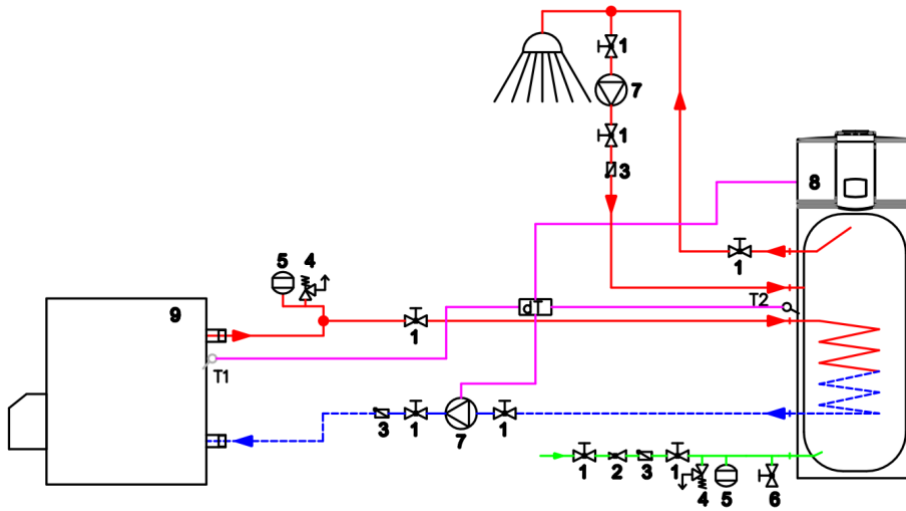

5.5.5 Electrical Connection

After the heat pump has been connected to the water supply and evacuated, the electrical connection is carried out.



ATTENTION

The connection cable can only be plugged into a grounded socket (16 A; 230 V a.c.).

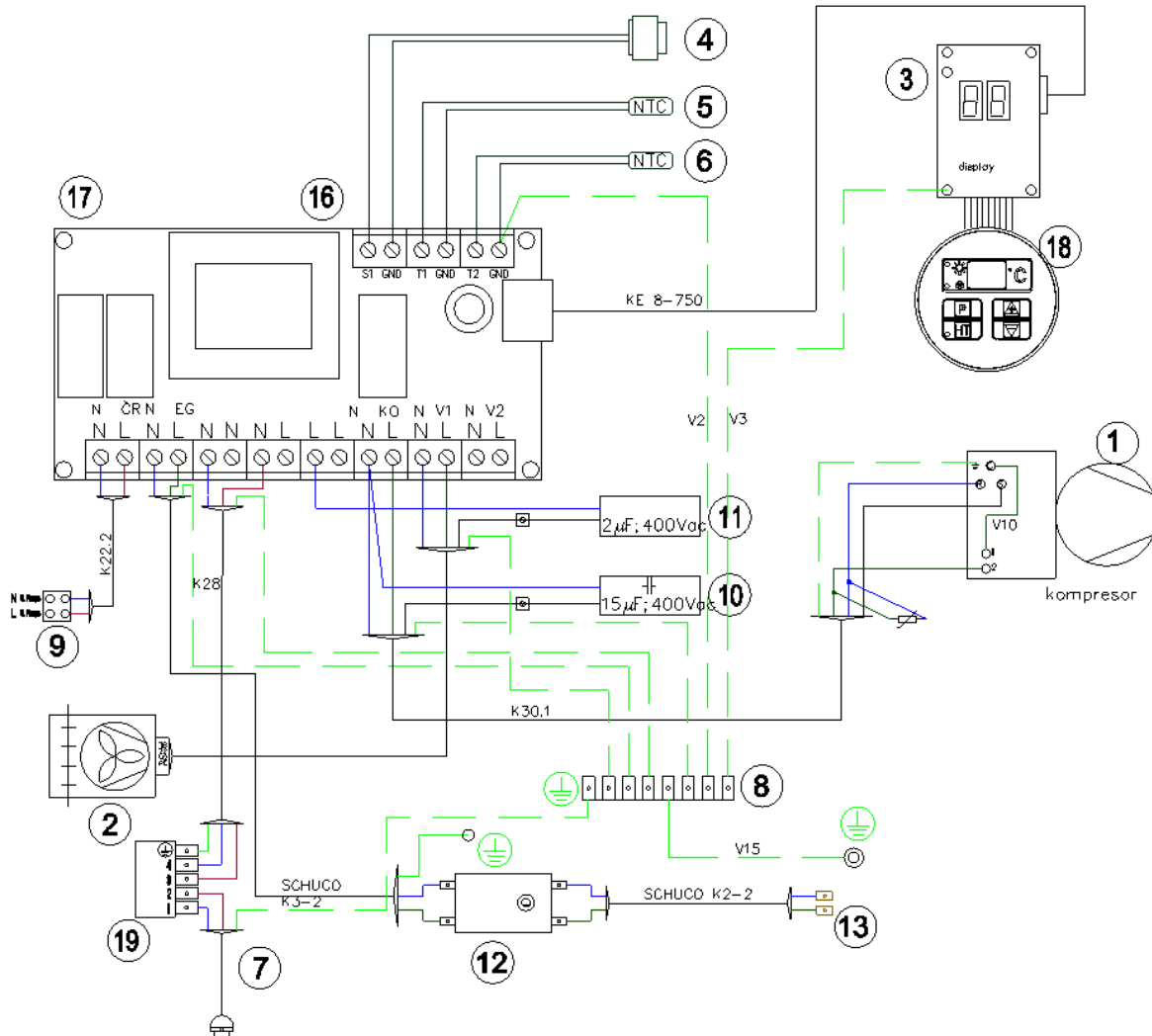

- | | | | |
|----|----------------------|----|-----------------------|
| 1 | Compressor | 11 | Fan capacitor |
| 2 | Fan | 12 | Safety thermostat |
| 3 | Display | 13 | Electrical heater |
| 4 | Pressure switch | 14 | Relay |
| 5 | NTC sensor - Water | 15 | Electromagnetic valve |
| 6 | NTC sensor - Air | 16 | PV signal |
| 7 | Power supply cable | 17 | Relay board |
| 8 | Ground | 18 | Keyboard |
| 9 | Pump | 19 | EMC filter |
| 10 | Compressor capacitor | | |

Electrical connection of the circulation pump and the PV signal.

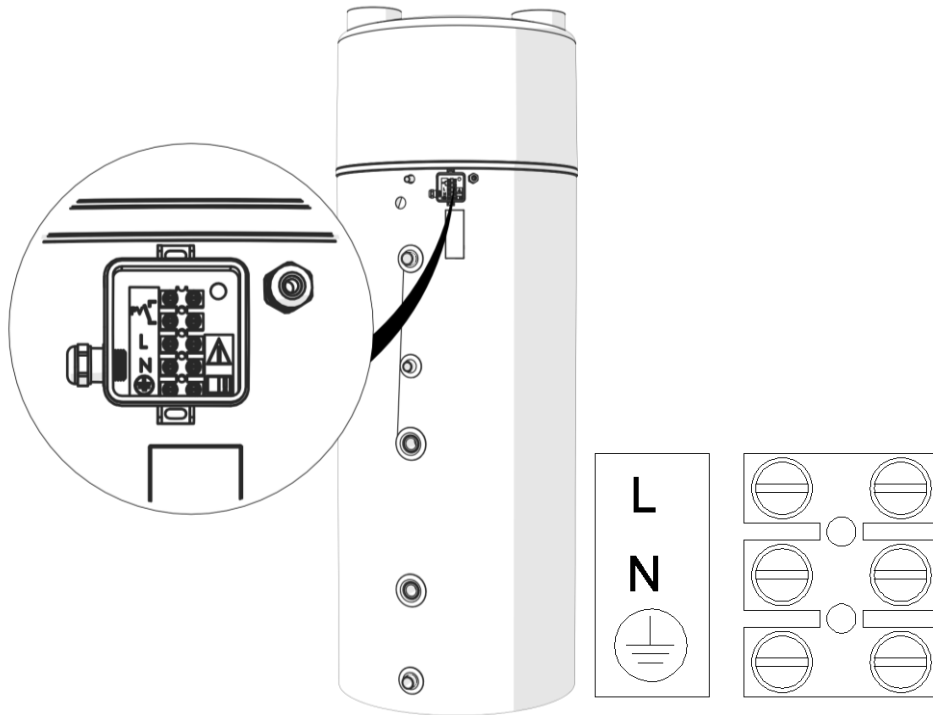

6 Heat Pump Start-up

6.1 Filling the System with Water

After the heat pump has been appropriately connected to the water supply by a qualified person, the system must be filled with water and thoroughly evacuated. This is carried out by opening all water pipes in the building. When the water is running without any bubbles, the system is properly filled and evacuated.



CAUTION

The heat pump must not be in operation if the water tank is empty, otherwise system failure may occur.

6.2 Control prior to Start-up

Before the device is started inspection of the following must be done:

- Water heater must be filled with water and thoroughly evacuated.
- All hydraulic connections must be firmly sealed.
- All safety elements must function properly.





6.3 Connection of the Heat Pump to the Power Network

The device is fitted with a standard connection cable. Before the start-up the connection cable must be plugged into a socket with a voltage of 230V a.c.

After the cable has been plugged in, the starting sequence is shown on the display. The settings are shown one after another.

If the starting sequence does not appear on the display, you must contact your customer service.

6.4 Start-up

- Modern and efficient presentation of the functioning of the system through digital display and light indicators.
- Two fast keys for the water temperature adjustment ( , ).
- Fast key for switching between operation modes ().
- Fast key for individual thermal disinfection (anti-legionella protection - over **60°C**) ().
- Defrost function at low air temperatures.
- Option of fast water heating (HP + el. heater).
- Automatic switch to a backup heating source if the temperatures are too low (el. heater or boiler)
- Automatic anti-legionella programme, automatic overheating of water over 60°C every 14 days (or in a time period from 1 to 99 days).
- Auto-diagnostic programme.
- Identification and display of errors during operation.

6.5 Heat Pump Operation

If the heat pump is properly connected to the voltage and water supply, the regulation version and the operating programme set by the manufacturer (e.g. P.1) appear on the display after 2 seconds, as well as all operational parameters and their values. 30 seconds after the device has been connected to the mains, the entire system is activated and starts to heat the water. The heat pump operates until it reaches the preset switch-off temperature (52°C) then it shuts-off automatically. When the water temperature drops to 48°C, the heat pump switches automatically back on. The user can freely lower or raise the switch-off temperature, the upper limit however is set to 55°C (regulator blockade). The overheating of water is limited to 60°C and cannot be adjusted. The ambient air temperature at which the system switches to the back-up heat source is set to 0°C, but can be adjusted by the user (see the following instructions).

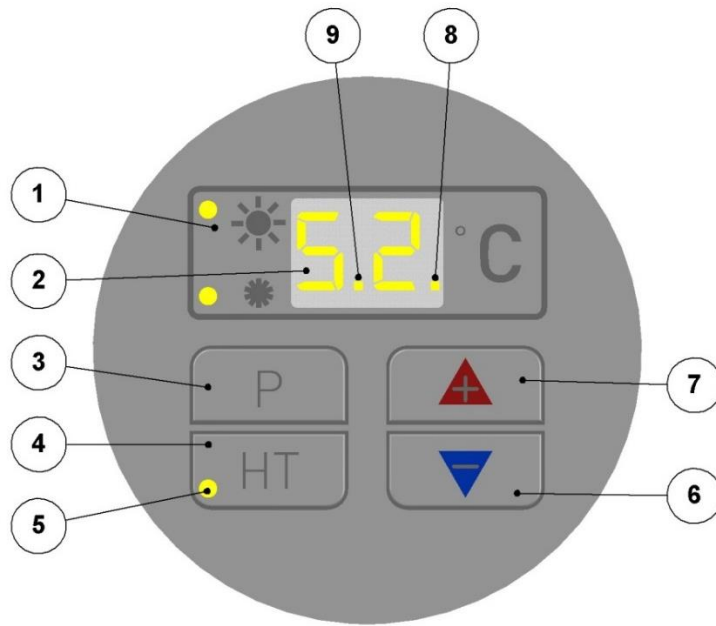

6.6 Settings







ID	Description
1	Indicator of operating mode
2	Temperature and parameter display
3	Button for mode selection.
4	Button for manual thermal disinfection and quick heating
5	Thermal disinfection and quick heating indicator
6	- Button for temperature and parameter selection
7	+ Button for temperature and parameter selection
8	Compressor start blockade indicator
9	Compressor minimal operating time indicator



Light indicators	Programme	DESCRIPTION
☀ not illuminated * not illuminated	P0	Operation of the heat pump is switched off; only display of the water temperature in the storage tank is active.
☀ illuminated * not illuminated	P1	Heat pump is heating water to the set temperature with the compressor only. If the inlet air temperature is too low, the compressor is switched off for safety reasons. Attention: In case of a defective air sensor, the error is indicated on the display, but the heat pump continues with the heating of water.
☀ not illuminated * illuminated	P2	The water in the water tank is heated to the set temperature by means of a heating boiler only. Note: the ambient air temperature has no influence on the operation.



<p>☀ not illuminated</p> <p>* flashing</p>	P3	<p>The water in the water tank is heated to the set temperature by means of an electric heater.</p> <p>Note: the ambient air temperature has no influence on the operation.</p>
<p>☀ illuminated</p> <p>* illuminated</p>	P4	<p>The heat pump is heating water to the set temperature with the compressor (automatic mode of operation). The operation of the heat pump depends on the air temperature. If the temperature falls below the switch-over temperature, the heating of water by means of a boiler takes place.</p>
<p>☀ illuminated</p> <p>* flashing</p>	P5	<p>The heat pump is heating water to the set temperature with the compressor (automatic mode of operation). The operation of the heat pump depends on the air temperature. If the temperature falls below the switch-over, the heating of water by means of an electric heater takes place.</p>
<p>Specific operation modes</p>		<p>In case of a switch-over to a back-up heat source (only P4 and P5).</p>
<p>☀ flashing</p> <p>* flashing or illuminated</p>	P4, P5	<p>If the inlet air temperature is too low or if the temperature falls below the switch-over temperature, the heating of water in P4 programme is performed by means of a boiler and in P5 programme with an electric heater. In this case, the compressor is out of operation for safety reasons.</p>

NOTE: BY PRESSING THE  KEY THE CURRENTLY SELECTER PROGRAMME IS SHOWN (this can also be seen from the light indicators – see the above table). WITH EACH FURTHER PRESSING OF THE  KEY WITHIN 8 SECONDS, WE SWITCH BETWEEN DIFFERENT AVAILABLE MODES OF OPERATION.

NOTE: BY CHOOSING THE PROGRAMME (SOURCE) WE ALSO DETERMINE THE HEAT SOURCE FOR THE OVERHEATING OF WATER.

1. Water temperature setting: By pressing the  or  key we see the currently set temperature, each further pressing of the  or  key (within 10 sec) causes the temperature value to change. Wait 5 sec and the new setting will be saved after the flashing stops.

2. Switching between different modes of operation: Switching between modes of operation is carried out by pressing the  key. Illuminated light indicator and a symbol shown on the display when pressing the  key (see the above table) indicate the selected program. With each further pressing of the  key within 8 seconds, we switch between different available modes of operation.

3. Single thermal disinfection: Overheating of water to over 60°C is carried out by pressing the  key (light indicator on the key is illuminated). When the overheating is finished, the light indicator is turned off. By pressing the  key once again, the overheating process can be interrupted early. We recommend an interval of 14 days and not more often, since the energy consumption is about 1/3 higher than when the HP is in normal operation.

Important: the overheating is carried out with the heat source determined by the selected operational program, e.g. P1 – compressor, P2 – boiler).



Note: in case the overheating is not carried out within 12 hours, the function is switched off and normal operation is switched on.

4. Fast water heating: Program P5 provides the function of fast (simultaneous) water heating, where both heat sources are operated (heat pump and electric heating element in P5 programme). This function is performed by pressing and holding the  key for 20 seconds. The light indicator on the HT key flashes until the set water temperature is reached. The function can be interrupted by pressing the HT key again.

Modes of operation

- 1. Water heating with the compressor only (P5):** the water is heated with the compressor, until the set temperature is reached or until the temperature of the inlet air remains above the min. operational temperature. When the temperature of the water in the water tank drops for 5°C, the compressor starts the heating process again. If the ambient air temperature falls below the selected value, the compressor switches off for about 30 minutes for safety reasons or until a higher ambient temperature is achieved. The heating of water is carried out in the P5 program by means of a compressor.
- 2. Water heating with the electric heater (P3):** the water is heated by means of the electric heater until the set water temperature is reached. The active and safety thermostat of the electric element is limited to 65°C. Because the temperature sensor is installed under the electric heating element, the temperature shown on the display can deviate from the actual set temperature.
- 3. Water heating with an active PV signal (P6):** The heat pump is heating water to the set temperature with the compressor (automatic mode of operation). The operation of the heat pump depends on the air temperature. In P6 programme the PV (photovoltaic) signal is also active, which means that the water is heated to a higher temperature (the set temperature + value set in parameter L6 up to max. 65°C). This mode of operation is only active if the PV signal is also active.
- 4. Bivalent operation:** When the heat pump is in bivalent operation, the water is additionally heated with an electric heater. The bivalent temperature is between +5°C and -5°C (parameter L1).





Parameter display and setting





We enter the parameter menu by shortly pressing the  and  key simultaneously. For browsing through the menu we use one of the keys individually.

8 seconds after the desired parameter has been selected, the value of the selected parameter is displayed for 10 seconds. After that the display reverts to the main menu and shows the current water temperature in the storage tank.

Parameter	Description	Range	Default settings
L0	Evaporation temperature in °C	-15 ÷ 95 °C	-
L1	Bivalent temperature in °C	-15°C – 30°C	-12
L2	Overheating time interval in days	1 – 99 days	14
L3	Customer service	-	-
L4	Switch-off temperature (hysteresis)	1°C to 20°C	5°C

L5	Operation of the electric heater due to low water temperature	--, 1°C to 55°C	-- (off)
----	---------------------------------------------------------------	-----------------	----------

Setting of the time interval of the automatic thermal disinfection/safety heating – anti-legionella protection: to enter the parameter display, we shortly press the  and  key simultaneously. For browsing through the menu we use the same keys individually (see chapter Parameter display). Select parameter L2 and after a few seconds the set time interval is displayed (14 days). While the set time interval is displayed, the values can be freely changed (from 1 to 99 days) by using the  or  key. 5 seconds after the desired value is selected the flashing of the light indicator stops and the settings are saved. We recommend an interval of 14 days and not more often, since the energy consumption is about 1/3 higher than when the HP is in normal operation.

Setting of the bivalent temperature (only in P5 programme): to enter the parameter display, we shortly press the  and  key simultaneously. For browsing through the menu we use the same keys individually. Select parameter L1 and after a few seconds the pre-set switch-off temperature (set to -5°C). While the set temperature is displayed, it can be freely changed by using the  and  key (from -9°C to +30°C). 5 seconds after the desired temperature is set the flashing of the light indicator stops and the settings are saved.

7 Dismantling and Removal

Taking into account the instructions for safe use and maintenance, the device as a whole has a designated life span of at least 8 years. However, life expectancy of individual components is variable, therefore they must be immediately replaced in case of malfunctions, wear and tear or mechanical damages.

Replacement can only be carried out by using technically compatible or original spare parts. At the end of the life span of the heat pump, the entire device must be deposited into landfill for industrial waste, according to the waste classification. Components harmful to the environment must be deposited at collecting points provided for this purpose.

8 Maintenance

8.1 General

If these instructions for safe use and maintenance are followed, the heat pump will function without any servicing procedures and additional maintenance.



ATTENTION

The device must be connected in accordance with the national regulations.

8.2 Care and Maintenance

8.2.1 Care



ATTENTION

The surface of the heat pump can be damaged! The use of inappropriate cleaning agents can cause surface damages. Do not use cleaning agents which can damage plastic surfaces. The use of solvents and chlorinated cleaning agents is prohibited. Use a wet cloth and soap if needed.

- Clean the heat pump with a non-abrasive moist cloth and a bit of soap.
- Do not use aggressive and chlorinated cleaning agents or solvents.

8.2.2 Maintenance

Recommended checks:

- Check the safety valve of the cold water connection – slightly unscrew the valve until the water starts to flow.
- Check the evaporator coil fins – the coil fins should not be dusty as this will generally reduce the efficiency of the heat pump. If, however, the coil fins become dusty, switch off the heat pump, loosen the screws, remove the top plastic cover and clean the fins with a vacuum cleaner or blow through them with air. Make sure that you do not damage the fins or any other part of the heat pump.



ATTENTION!

The coil fins are very sharp. Negligent cleaning can cause personal injuries.

Check before reporting defects to the Customer Service:

- Check if everything is in order with the electrical connection lines.
- Check if the air outlet from the evaporator is obstructed by the grid.
- Measure the room temperature where the heat pump is installed and make sure that the temperature is consistent with the prescribed temperature.

The customer service must check the Mg-anode in the water heater every two years. It is recommended that in this time period the heat pump is also cleaned.

9 Disturbances in the Functioning

9.1 Warning signs

Warning signs		
A1	Temperature of the inlet air is too low; the heat pump is deactivated.	The room should be ventilated so that the temperature rises above the switch-off

		value and the heat pump will restart automatically.
		If the room temperature is constantly under the set switch-off value, a different installation room should be selected.
A3	The inlet air temperature is too high (40°C); the heat pump is deactivated.	<p>The room should be ventilated so that the temperature falls below this value and the heat pump will restart automatically.</p> <p>If the room temperature is constantly above this value, a different installation room should be selected.</p>

9.2 Error Indication

Error	Cause	Solution
E7	Pressure in the system is too high.	<p>Check if there is enough water in the water heater.</p> <p>Error is deleted by pressing the + key. If the error occurs again, call the repair service.</p>
Alternately E8 and --	DHW sensor is disconnected.	Check if the sensor is connected. If not, contact the repair service.
Alternately E8 and --	Malfunction of the DHW sensor.	First, reset the heat pump and check the connection cable of the sensor. If the error occurs again, contact the repair service.
Alternately E9 and --	Evaporation temperature sensor is disconnected.	Check if the sensor is connected. If not, contact the repair service.
Alternately E9 and --	Malfunction of the evaporation temperature sensor.	First, reset the heat pump and check the connection cable of the air sensor. If the error occurs again, contact the repair service.
Description of malfunction	Cause	Solution
Water is not heated to the set temperature.	Boiler heating circuit is not closed.	Close the valve of the boiler circuit.
	Circulation takes too much heat.	Switch off the circulation pump and close the valve.
	Gas leakage somewhere in the system.	Contact the repair service.
	Damaged evaporator due to careless cleaning.	Contact the repair service.
HP is constantly in operation and does not switch off.	Insufficient amount of gas in the system.	Contact the repair service.
	Circulation takes too much heat.	Switch off the circulation pump and close the valve.
	Uncontrolled heat discharge from the boiler (hot water consumption is too high).	Check all possible sources of heat consumption from the boiler.
HP causes too much noise.	The fan is in contact with the housing or the protective grid.	Contact the repair service.
	Compressor malfunction.	
Electric heater does not work.	Regulator displays the water temperature below the electric heater that is why the displayed temperature is not correct.	Check if the tap water is hot.
Evaporator freezing.	Insufficient air flow through the evaporator.	Air intake and discharge must be unobstructed.
	Fan malfunction.	Contact the repair service.

10 Warranty, Guarantee and Product Liability

The warranty is granted in accordance with the statutory provisions of the Republic of Austria, as well as of the EU.

1. Prerequisite for the provision of warranty services by Austria Email AG (hereinafter referred to as AE AG) shall be the presentation of the paid invoice for the purchase of the device for which the warranty service is claimed, whereby the identity of the device with regard to the model and the manufacturing number must be evident from the invoice and must be documented by the claimant. The General Terms and Conditions, Terms and Conditions of Sale and Delivery of AE AG shall apply exclusively.
2. To the extent required by the law, respectively in the Operator's Manual and Installation Instructions, the assembly, erection, connection and commissioning of the unit for which the claim is presented must have been carried out by a licensed electrician or installation firm, duly observing all applicable rules. The tank (without outer shell and plastic outer shell) must be protected from sunshine to avoid discolouring of the PU foam and potential warping of plastic components.
3. The room in which the device is operated must be free of frost. The unit must be mounted in a location that may reasonably be expected, i.e. it must be possible to access and replace the unit without difficulty for the purpose of necessary maintenance, repairs and possible replacement. The costs for any necessary changes to the structural conditions (e.g. doors and passages too narrow) are not governed by the guarantee and warranty declaration and therefore shall be rejected on the part of AE AG. If the water boiler is set up and operated in uncommon locations (e.g. attics, living rooms with water-sensitive floors, store rooms, etc.), the possibility of water leakage must be taken into account and provisions made for collecting and discharging the water leakage in order to prevent secondary damage within the meaning of product liability.
4. The following is not covered by the warranty and guarantee: inappropriate transport, normal wear and tear, intentional or negligent damage, use of force of any kind or description, mechanical damage or damage caused by frost or also by exceeding the operating pressure stated on the rating plate, even if only once, use of connection fittings that do not comply with the standard, use of defective tank connection fittings and unsuitable and defective service fittings. Breaking of glass and plastic components, possible colour differences, damage due to improper use, in particular non-observance of the mounting and operating instructions (Operating and Mounting Instructions), damage by external influence, connecting to incorrect voltage, corrosion damage as a consequence of aggressive waters (water not suitable for drinking) in accordance with the national regulations (e.g. Austrian ordinance on drinking water, TWV – Fed. Law Gazette II No. 304/2001), deviations between the actual drinking water temperature at the tank fitting and the specified hot water temperature of up to 10°K (hysteresis of the controller and possible cooling due to pipelines), insufficient water conductivity (min. 150 µs/cm) operational wear of the magnesium anode (wearing part), natural formation of boiler scale, lack of water, fire, flood, lightning, overvoltage, power failure or other types of force majeure. Use of non-original and company-external components such as e.g. heating elements, reactive anode, thermostat, thermometer, ribbed tube heat exchanger, etc., Parts installed in an uninsulated condition with respect to the storage tank, ingress of foreign particles or electrochemical influences (e.g. mixed installations), failure to observe the design documents, unpunctual and undocumented renewal of the installed protective anode, no or improper cleaning and operation, as well as any deviations from the standard that reduce the value or functionality of the device only slightly. Fundamental compliance with all regulations in ÖNORM B 2531, DIN 1988 (EN 806), DIN 1717, VDI 2035 or the corresponding national regulations and laws must be ensured.
5. In the case of an authorised complaint, this must be reported to the next available customer service location of AE AG. The same reserves the right to decide whether a defect component shall be replaced or repaired or whether a defect device shall be replaced by an equivalent fault-free device. Furthermore, AE AG explicitly reserves the right to request that the rejected device be returned by the buyer.
6. Repairs under warranty must be performed exclusively by persons authorised to do so by AE AG. Replaced parts shall remain the property of AE AG. If a repair of the hot water heater should be required in connection with necessary service work, the Manufacturer shall invoice these as repair and prorated material costs.
7. Any intervention by third parties without our express instruction, even if performed by a licensed electrician, shall have the effect of voiding the warranty. Costs for repairs carried out by third parties shall be replaced only if AE AG has previously been requested to remove the defect and if AE AG shall have failed to satisfy its obligation to replace the defective item or repair the defect or if it shall have failed to do so within a reasonable period of time.
8. Neither the performance of works under warranty or guarantee, nor the performance of service and maintenance works shall renew or extend the term of warranty.
9. Transport damage shall be investigated and possibly accepted only if it is reported to AE AG in writing on the next following workday after delivery at the latest.
10. Claims over and above the warranty, if legally permissible, in particular claims with respect to compensation of damages and consequential damages, shall be excluded. Prorated labour time for repairs as well as the costs of restoring the original condition of the unit must be paid in full by the buyer. In accordance with this warranty declaration, the warranty shall apply only to repair or replacement of the unit. The provisions of the Terms and Conditions of Sale and Delivery of AE AG shall, unless amended by these Terms and Conditions of Warranty, remain fully in place.
11. Services that are not performed within the scope of these Terms and Conditions of Warranty shall be charged.
12. No claims under warranty shall be considered by AE AG unless full payment for the device has been made to AE AG and unless the claimant has fully satisfied all obligations arising to him vis-à-vis the seller.
13. The enamelled internal boiler for water heaters is warranted for the specified period from the delivery date provided all warranty terms described under Points 1 to 12 are observed with in full. If the warranty terms have not been met, the legal warranty requirements of the respective country from which the appliance was shipped shall prevail.
14. With regard to the assertion of claims pursuant to the Austrian Product Liability Act it must be noted: Potential claims under the title of product liability relating to the regulation of damages due to a defective product (e.g. a human's body is injured, his health is damaged or any corporeal property differing from the product is damaged) shall only be justified if all the prescribed measures and requirements for flawless and normal operation of the unit have been fulfilled. These include e.g. the mandatory and documented anode replacement, the connection to the correct operating voltage, any damage due to improper use must be avoided, etc. These standards are based on the assumption that if all the regulations (standards, assembly and operating instructions, general guidelines, etc.) are observed, the defect in the unit or product causal for occurrence of the secondary damage would not have occurred. It is further imperative that all the documentation necessary for handling of a claim, such as e.g. the type and fabrication number of the unit, the vendor's invoice and the invoice of the licensed electrician or installation firm, as well as a description of the malfunction be provided, as well as the defective unit itself for examination in the lab (absolutely necessary, as the unit will be investigated by an expert and the cause of the defect analysed). In order to exclude any possibility of mistaken identity of the unit during transportation, the unit must be labelled with a clearly legible label (ideally with the end customer's address and signature). Appropriate photographic documentation of the extent of damage, the installation (cold water inflow, hot water outflow, heating inflow and outflow, safety fittings, expansion vessel if applicable), as well as the defective part of the tank is required. AE AG further expressly reserves the right to demand the submission of documentation and units or unit components by the buyer for the purpose of clarification. The damaged party's full burden of proof that the damage was caused by the product of AE AG is prerequisite for the payment of any benefits under the title of product liability. Claims for damages pursuant to the Austrian Product Liability Act are moreover justified only for any amount exceeding the amount of 500 euros (deductible amount). Until all the facts and circumstances as well as the problem causally underlying the defect have been ascertained, any possible fault on the part of AE AG shall be ruled out explicitly. Any non-observance of the operating and assembly instructions as well as the relevant standards shall be deemed negligence and shall result in an exclusion of any liability for damages.

The figures and data are not binding and may be amended without notice in the interest of technical improvement.
Misprints and technical changes reserved.

Head office and factory:

Austria Email AG

A-8720 Knittelfeld, Austria Straße 6

Tel.: (03512) 700-0, Fax: (03512) 700-239

Internet: www.austria-email.at

E-Mail: office@austria-email.at

Customer service Tel.: (03512) 700-297

E-Mail.: kundendienst@austria-email.at

Sales office addresses:

Wien, Niederösterreich, Burgenland

A-1230 Wien, Zetschegasse 17

Tel.: (01) 615 07 27

Fax: (01) 615 07 27-260

E-Mail: bhrastnik@austria-email.at

Steiermark, Kärnten, Osttirol

A-8053 Graz, Am Wagrain 62

Tel.: (0316) 271 869

Fax: (0316) 273 126

E-Mail: gbretterklieber@austria-email.at

Oberösterreich, Salzburg

A-4600 Wels, Gärtnerstraße 17

Tel.: (07242) 45 071

Fax: (07242) 43 650

E-Mail: akweton@austria-email.at

Tirol, Vorarlberg

A-6020 Innsbruck, Etrichgasse 24

Tel.: (0512) 347 951

Fax: (0512) 393 353

E-Mail: hruapp@austria-email.at